

K3R110  $\pm 5\text{kN}/100\text{Nm}/\text{VA}$

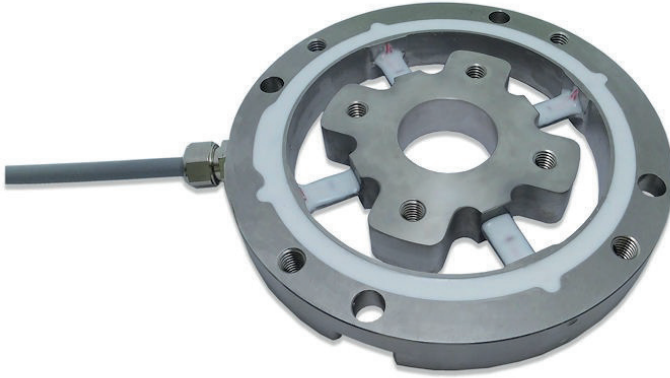

### Description

The force sensor K3R110 is very well suitable for testing tasks in the quality assurance and in the material testing due to its compact design.

This precision force sensor distinguishes itself by flat construction of only 20 mm thickness.

By the sensor K3R110 the connections of 4 strain gauge measuring springs are separately brought out.

By setting the four measuring signals it is possible to determine the axial force and the bending moment  $M_x$  and  $M_y$  around the x- and y-axes with the sensor.

The distance of the force transmission from the sensor surface helps to set the bending moments  $M_x$  and  $M_y$  and also horizontal forces  $F_x$  and  $F_y$ .

With the help of calibration matrix the simple processing of the sensor signals to forces and moments will be achieved.

Dimensions

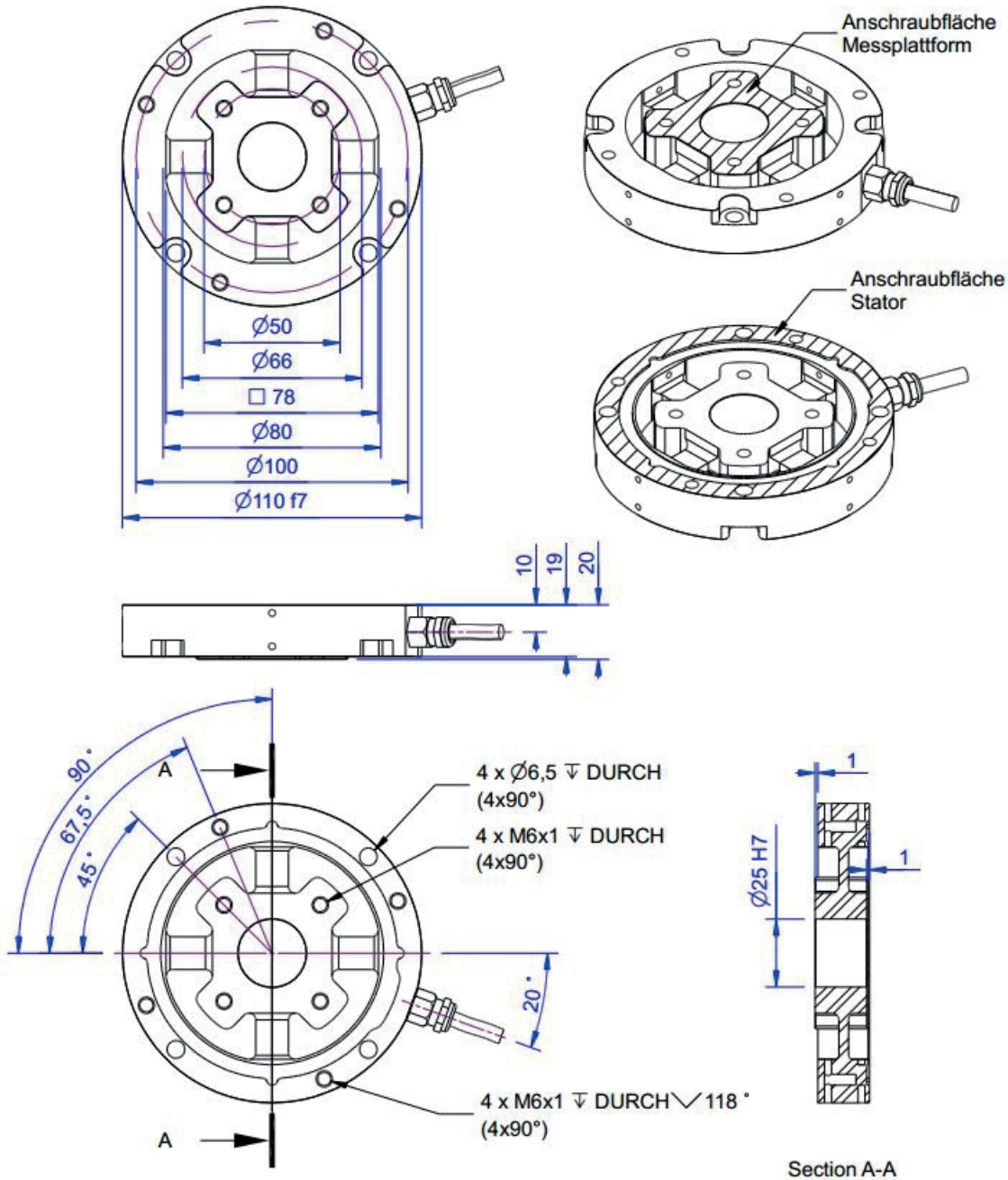

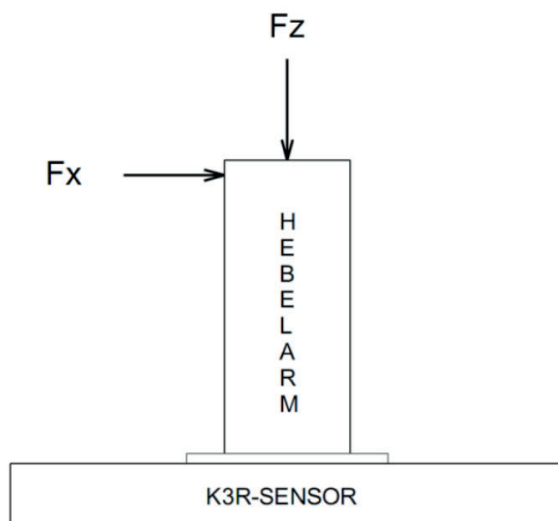
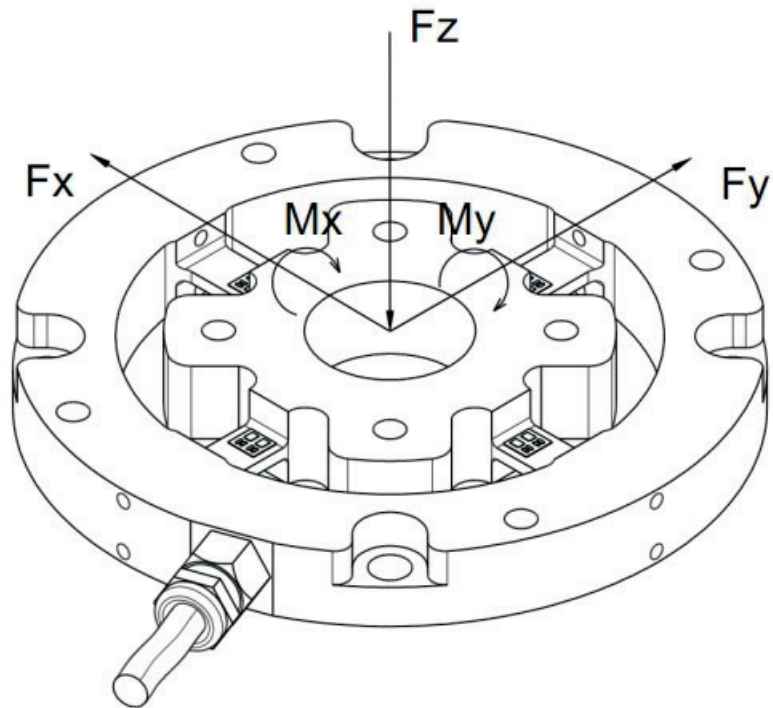

Anwendung als 3D Kraftsensor

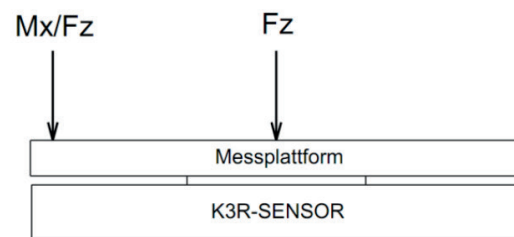

Anwendung als Kraft - Momenten Sensor

bzw. Kraft-Schwerpunkt Sensor

## Technical Data

### Force sensor

Type	3-axis force sensor
Force direction	Tension / Compression
Rated force Fz	5 kN
Force introduction	Inner thread
Dimension 1	4x M6x1
Sensor Fastening	Inner thread
Dimension 2	4x M6x1
Operating force	150 %FS
Rated displacement	0.1 mm
Material	Stainless steel
Dimensions	Ø 110 x 20 mm x mm
Height	20 mm
Length or Diameter	110 mm
Rated torque Mx	100 Nm
Rated torque My	100 Nm
Torque limit	200 %

### Electrical Data

Input resistance	87 Ohm
Tolerance input resistance	2 Ohm
Output resistance	350 Ohm
Tolerance output resistance	5 Ohm
Insulation resistance	2 GOhm
Rated range of excitation voltage f	2.5 ... 5 V
Operating range of excitation voltage f	1 ... 5 V
Zero signal	0.05 mV/V
Rated output	1 mV/V / FS

### Precision

Accuracy class	0,1%
Relative linearity error	0.1 %FS
Relative zero signal hysteresis	0.1 %FS
Temperature effect on zero signal	0.01 %FS/K
Temperature effect on characteristic value	0.01 %RD/K
Relative creep	0.1 %FS

### Connection Data

Connection type	10-Leiter offen
Name of the connection	ME-SYSTEME.DE 24-10 PUR / 10x0,14
Cable length	3 m

### Temperature

Rated temperature range f	-10 ... 70 °C
---------------------------	---------------

Operating temperature range f	-10 ... 85 °C
Storage temperature range f	-10 ... 85 °C
Environmental protection	IP66

Abbreviation : RD: „Reading“; FS: „Full Scale“;

1) The exact rated output is reported in the test report .

### Pin Configuration

Channel	Symbol	Description	Wire colour
1	+Us	positive bridge supply	brown
	-Us	negative bridge supply	white
	+Ud	positive bridge output	green
	-Ud	negative bridge output	yellow
2	+Us	positive bridge supply	nc
	-Us	negative bridge supply	nc
	+Ud	positive bridge output	gray
	-Ud	negative bridge output	pink
3	+Us	positive bridge supply	nc
	-Us	negative bridge supply	nc
	+Ud	positive bridge output	blue
	-Ud	negative bridge output	red
4	+Us	positive bridge supply	nc
	-Us	negative bridge supply	nc
	+Ud	positive bridge output	black
	-Ud	negative bridge output	purple

Screen - transparent.

Pressure load : positive output signal;

nc: not occupied

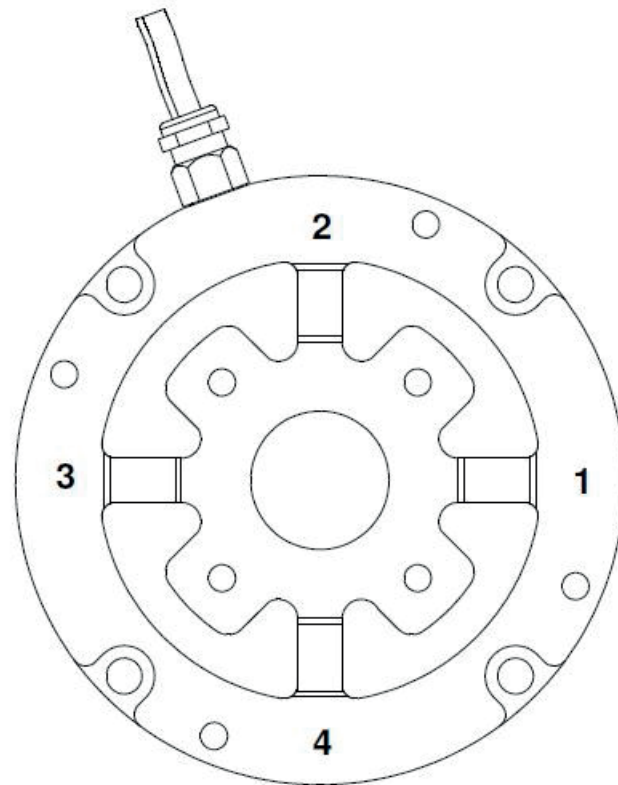

Description of channels

Mounting

Variant table

Variant	50N	100N	200N	200N VA	500N VA	1000N VA
Fz in N	50	100	200	200	500	1000
Mx in Nm	1	2	4	4	10	20
My in Nm	1	2	4	4	10	20

Calibration matrix

Application as 3D Force-Torque Sensor

	Ch1	Ch2	Ch3	Ch4
Fz	+100N / 1mV/V	+100N / 1mV/V	+100N / 1mV/V	+100N / 1mV/V
Mx	0Nm / 1.5 mV/V	-2Nm / 1.5mV/V	0Nm / 1.5 mV/V	+2Nm / 1.5mV/V
My	+2Nm / 1.5mV/V	0Nm / 1.5 mV/V	-2Nm / 1.5 mV/V	0Nm / 1.5 mV/V

With the 12 elements of the calibration matrix **A** the relationship between the output signal **U** = (U1, U2, U3, U4) of the sensor and the load vector **L** (Fz, Mx, My) is established:

$$\mathbf{L} = \mathbf{A} \times \mathbf{U}$$

Manual: <http://www.me-systeme.de/docs/de/manuals/a5/ba-k6d.pdf>

The measuring amplifier GSV-8 or the software GSV multi have the appropriate mathematical functions.

Application as Force / Focus Sensor

Alternatively can be calculated the focus of force transmission.

For the coordinates  $s_x$  and  $s_y$  (distance from center in x- and y- directions) is valid:

$$s_x = M_x / F_z$$

$$s_y = M_y / F_z$$

Application as 3D Force Sensor



If the distance  $s_z$  from the sensor surface is known, the torques  $M_x$  and  $M_y$  can be converted into appropriate forces  $F_y$  and  $F_x$ :

$$F_y = M_x / s_z$$



Fx = My / sz

accessories

	Description	Description
	Configuration D-Sub44/m/HD	Assembling the connector to sensor cable; Connector Type SubD, 44 pins, male (male), with hood
	K3R-CalibrationMatrix	Calibration matrix with 12 calibration factors for scaling of the sensor output signals on forces Fz and moments Mx and My.
	GSV-8DS	8-channel amplifier with USB port, analog output, UART interface. Other versions GSV-8AS CAN with Canbus and GSV-8AS EC with EtherCAT fieldbus.

Order options

Type	Description
------	-------------