

Torque Sensor

DRFSK

Very short!

Torque ranges from 2 Nm to 20 Nm

Hex drive

Suitable for motor vehicle,
test bench and assembly technology

Suitable for impulse tools

Optional angle measurement



Features

- Short form, especially suitable for automatic screwing machines
- Quick-release coupling
- Measurement, adjustment and examination without removing the screwing tool
- Frequency modulation and strain gauge principle cause high accuracy
- Suitable for clockwise and counter-clockwise measurement
- High interference rejection because of amplified active signal
- No service needed because of contact-less data acquisition
- High accuracy because frequency modulation and DMS principle
- Ordinary power supply
- Integrated chip for sensor detection
in connection with evaluation unit GMV2 or ValueMasterBase

Electrical Specifications DRFSK

Torque ranges (Nm):	2 5 10 12 15 20
Power consumption:	12 V DC ± 10 %
Current consumption:	approx. 200 mA (DRFSK-w approx. 225 mA)
Rise time 10-90 %:	1 ms (1 kHz)
Voltage output:	0 to ± 5 V
Internal resistance:	100 Ω
Ripple:	< 100 mVpp
Nonlinearity:	< 0,15 %
Hysteresis:	< 0,1 %
Max. measurement error:	< 0,15 %
Deviation at zero point:	≤ ± 100 mV
Operating temperature:	0 - 60 °C
Compensated temperature range:	5 - 45 °C
Temperature error	
Zero point:	0,02 % / K
Sensitivity:	0,01 % / K
Output signal:	± 5 V
Speed max:	10.000 min ⁻¹
Protection:	IP40
Weight approx.:	280 g
Connection:	12pin- connector
Calibration: Works certificate with 25% steps cw. Other calibrations upon request.	

Angle option (w)	
Max. rev.:	3000 min ⁻¹
Output:	open-collector
Internal pull up:	10 kΩ (5 V Pegel)
External pull up:	24 V max.
I _{max} :	20 mA
Pulses / rev.:	360
Resolution:	1°

Detection of direction of rotation
2 Imp. 90° Phase shift
Channel A clockwise of the of the drive side leading

Ordering Code

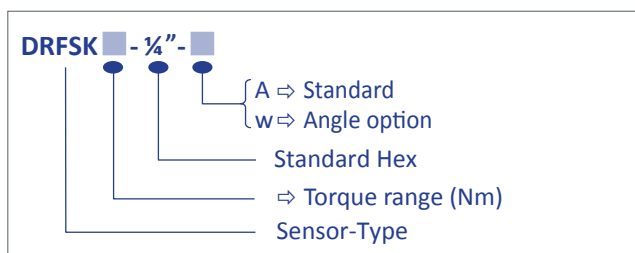

Accessories

Analyzer: GMV2
ValueMasterBase

Cables

Mechanical Dimensions DRFSK

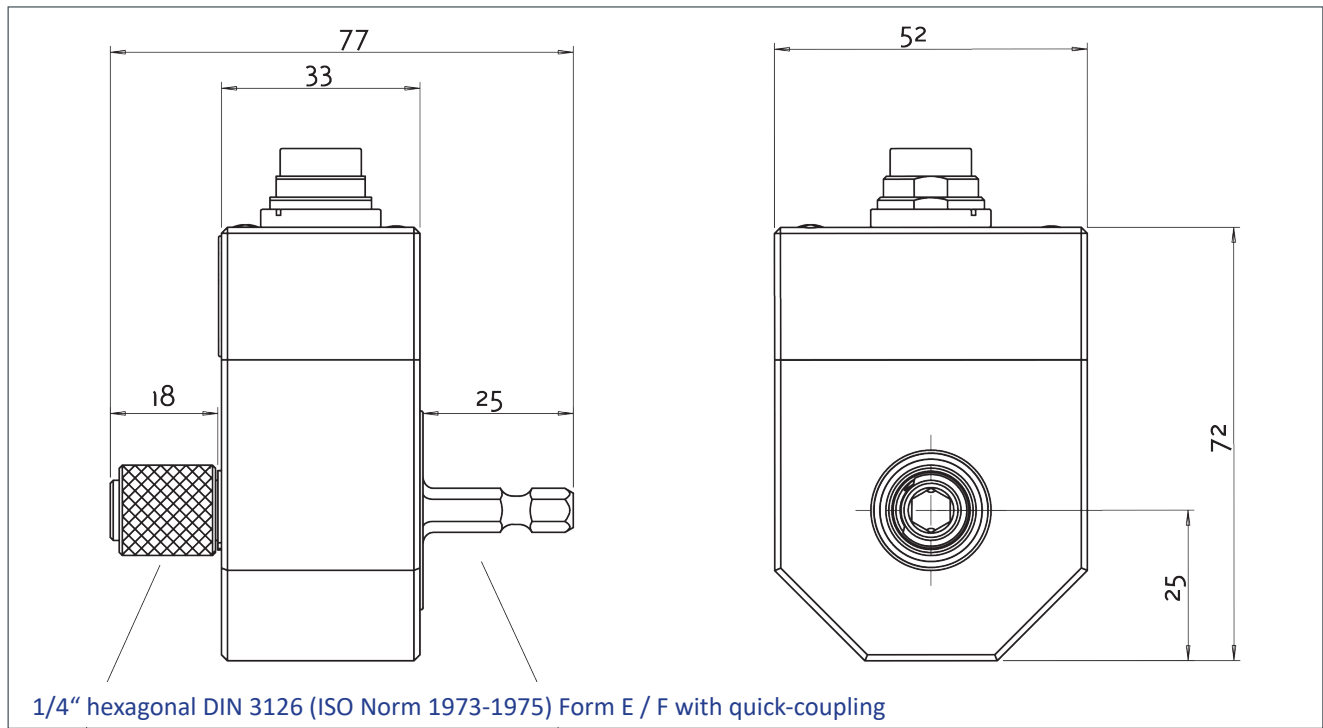

General tolerances DIN 2768-m

Technical Specifications DRFSK

Torque range (Nm)	Spring constant C (Nm/rad)	Mass moment of inertia J (g•cm ²)	Rated axial load (N)	Rated radial load (N)	Mechanical overload
2	370	60	21	21	100%
5	980	60	53	53	100%
10	1630	60	104	104	80%
12	1740	60	115	115	30%
15	1740	60	115	115	30%
20	1740	60	115	115	30%

Technical Specifications DRFSK-w (with angle measurement)

Torque range (Nm)	Spring constant C (Nm/rad)	Mass moment of inertia J (g•cm ²)	Rated axial load (N)	Rated radial load (N)	Mechanical overload
2	389	29	197	25	100%
5	1160	29	197	60	100%
10	2245	30	197	120	80%
12	2451	30	197	140	30%
15	2451	30	197	140	30%
20	2451	30	197	140	30%